**Agilent 10737L and Agilent 10737R
Compact Three-Axis Interferometers**

Description

Description

NOTE

In this subchapter refers to either or both of the Agilent 10737L and Agilent 10737R interferometers.

The Agilent 10737L/R Compact Three-Axis interferometers (see figures 7O-1 through 7O-3) allow up to three measurements (displacement, pitch, and yaw) to be made on a single axis. The Agilent 10737L and Agilent 10737R interferometers are identical except that the “L” bends the measurement beams to the left and the “R” bends the beams to the right, as viewed from the incoming beam (see figures 7O-2 and 7O-3).

These interferometers are designed to use a 3 mm diameter laser beam, available from an Agilent 5517C-003 Laser Head.

The measurement beam parallelism inherent in the design of the Agilent 10737L/R interferometers ensures that there is essentially no cosine error between their three measurements and also ensures angle accuracy for pitch and yaw measurements.

These interferometers are designed for direct attachment of Agilent 10780F-037 Remote Receiver’s fiber-optic sensor head (one per axis). The Agilent 10780F-037 receiver is the same as the standard receiver, except it does not include the lens assembly that attaches to some Agilent interferometers; in this case, the required lens assembly is part of the Agilent 10737L/R interferometer. This simplifies user assembly, since no optical alignment of the receiver is required. The fiber-optic cables from the receivers attach directly to the axis output apertures on the input face of the interferometer. See figures 7O-2 and 7O-3.

The Agilent 10737L/R interferometers are based on the Agilent 10706B High-Stability Plane Mirror Interferometer’s design. Figure 7O-1 shows two views of an Agilent 10737L interferometer. In addition to the Agilent 10706B components, the interferometer includes the following assemblies:

- The receiver assembly. This can be removed during alignment using the 4-40 socket-head cap screws. The 4-40 button-head screws hold the 0.100-inch-thick cover plate and the receiver assembly parts in place; do not try to loosen these screws or remove the plate.
- The shear plate assembly. This assembly is factory-aligned and must not be loosened or removed.

Description

- The corner cube assembly. This assembly is factory-aligned to produce the required beam pattern. Do not remove the corner cube assembly or loosen the screws holding the assembly in place. Moving this assembly will change the output beam pattern.

- 1 Corner cube assembly
(Do not loosen or remove)
- 2 Reference mirror or high stability adapter
- 3 Plane mirror converter
- 4 Polarizing beam splitter
- 5 Shear plate assembly
(Do not loosen or remove)
- 6 Receiver assembly
- 7 4-40 socket-head cap screws attaching receiver assembly

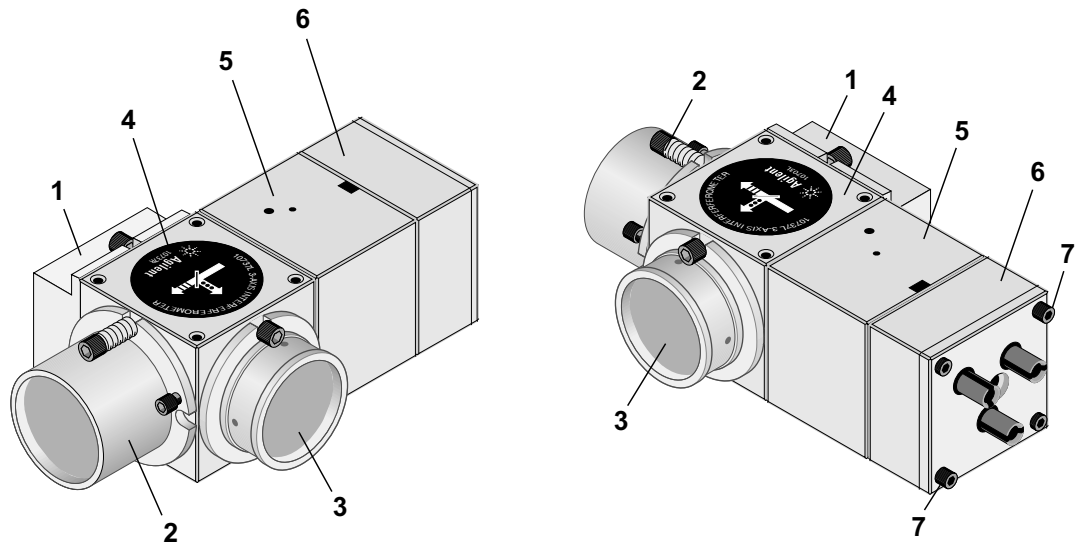

Figure 70-1. Agilent 10737L Compact Three-axis Interferometer

Description

AGILENT 10737L COMPACT THREE-AXIS INTERFEROMETER

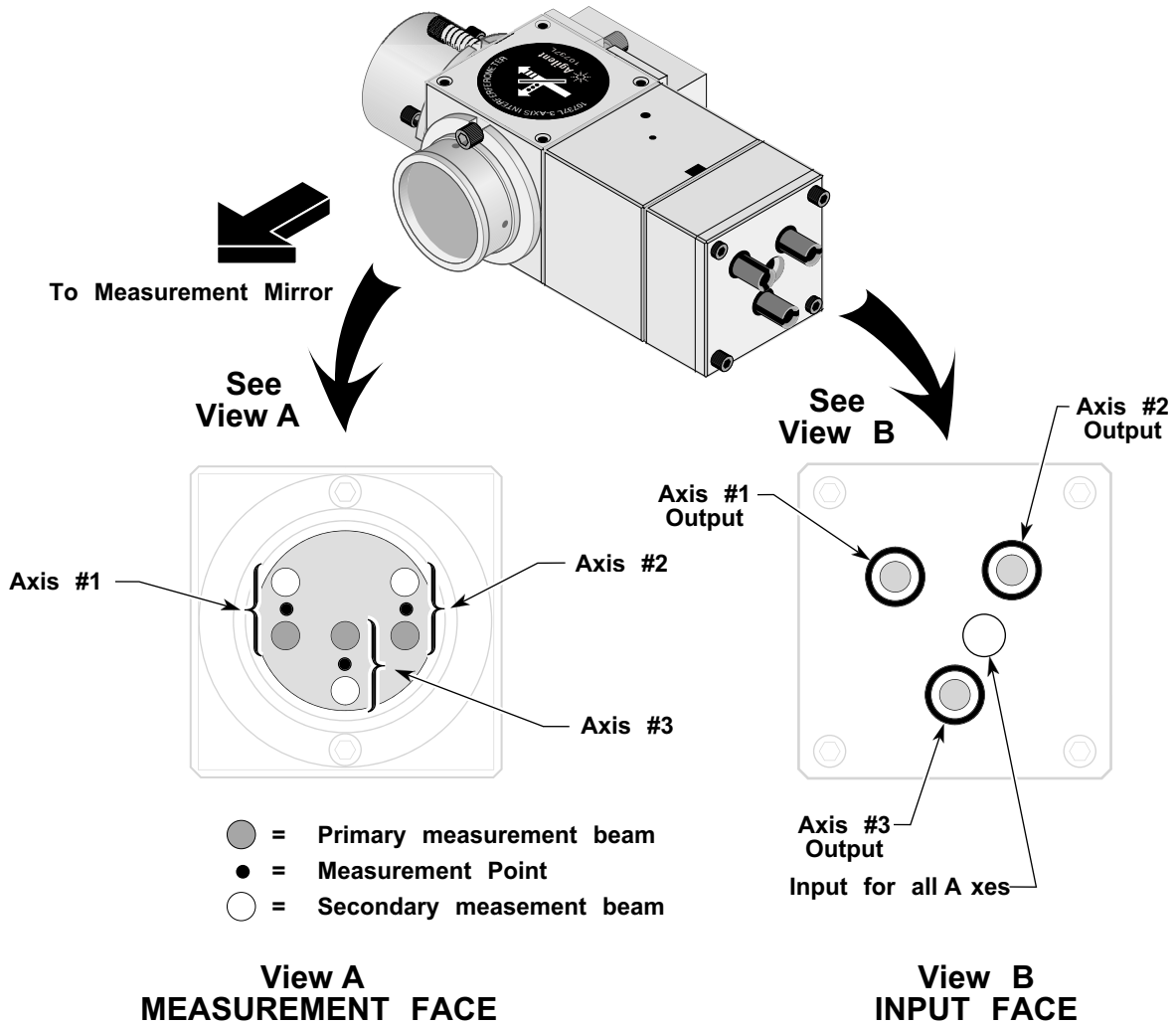

Figure 70-2. Agilent 10737L Compact Three-Axis Interferometer

Description

AGILENT 10737R COMPACT THREE-AXIS INTERFEROMETER

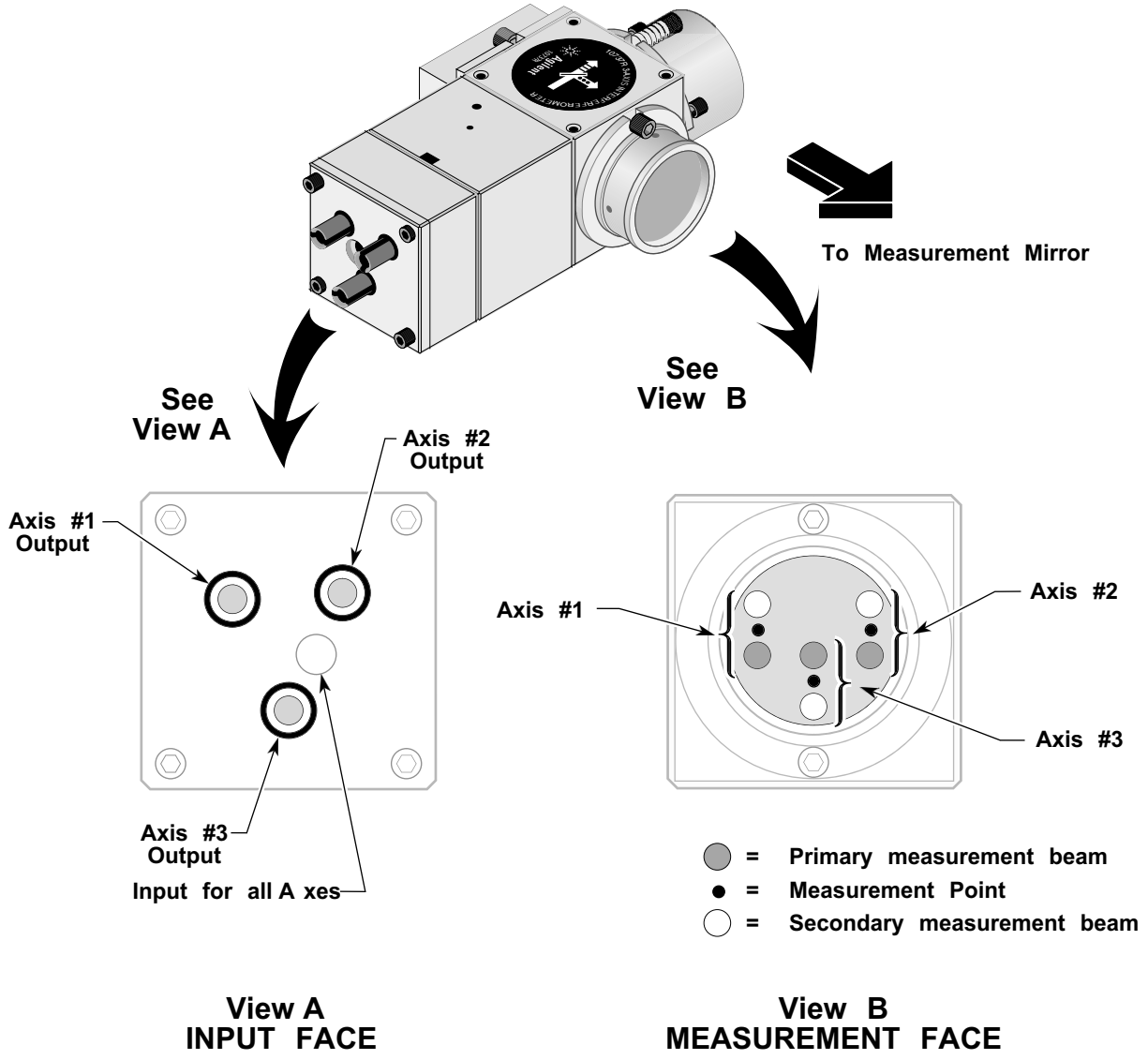

Figure 70-3. Agilent 10737R Compact Three-Axis Interferometer

Description

Applications

General

The Agilent 10737L or Agilent 10737R interferometer, by making three simultaneous distance measurements along or parallel to the X-axis, can make these measurements:

- displacement along the X-axis
- rotation (pitch) about the Y-axis
- rotation (yaw) about the Z-axis

The angular measurements made by either of these interferometers can be calculated by taking the arctangent of the difference between two linear measurements involved, divided by their separation:

$$\text{THETA} = \arctan \frac{(Y - Y')}{D}$$

This method for determining angle is described in more detail in the “Electronic yaw calculation method” and “Optical yaw calculation method” subsections under the “Three-axis system using discrete plane mirror interferometers (X, Y, YAW)” section in Chapter 3, “System Design Considerations,” of this manual.

X-Y Stage

These interferometers are well suited for X-Y stage or multiaxis applications, such as lithography equipment. Two of these interferometers, can measure all X, Y, pitch, roll, and yaw motions of a stage. Since only five axes are required to make all these measurements, the sixth axis can be used as a redundant yaw measurement (useful for mirror mapping). In these applications, the measurement mirrors are attached to the X-Y stage.

Description

MEASUREMENT USING AGILENT 10737R/L COMPACT THREE-AXIS INTERFEROMETERS

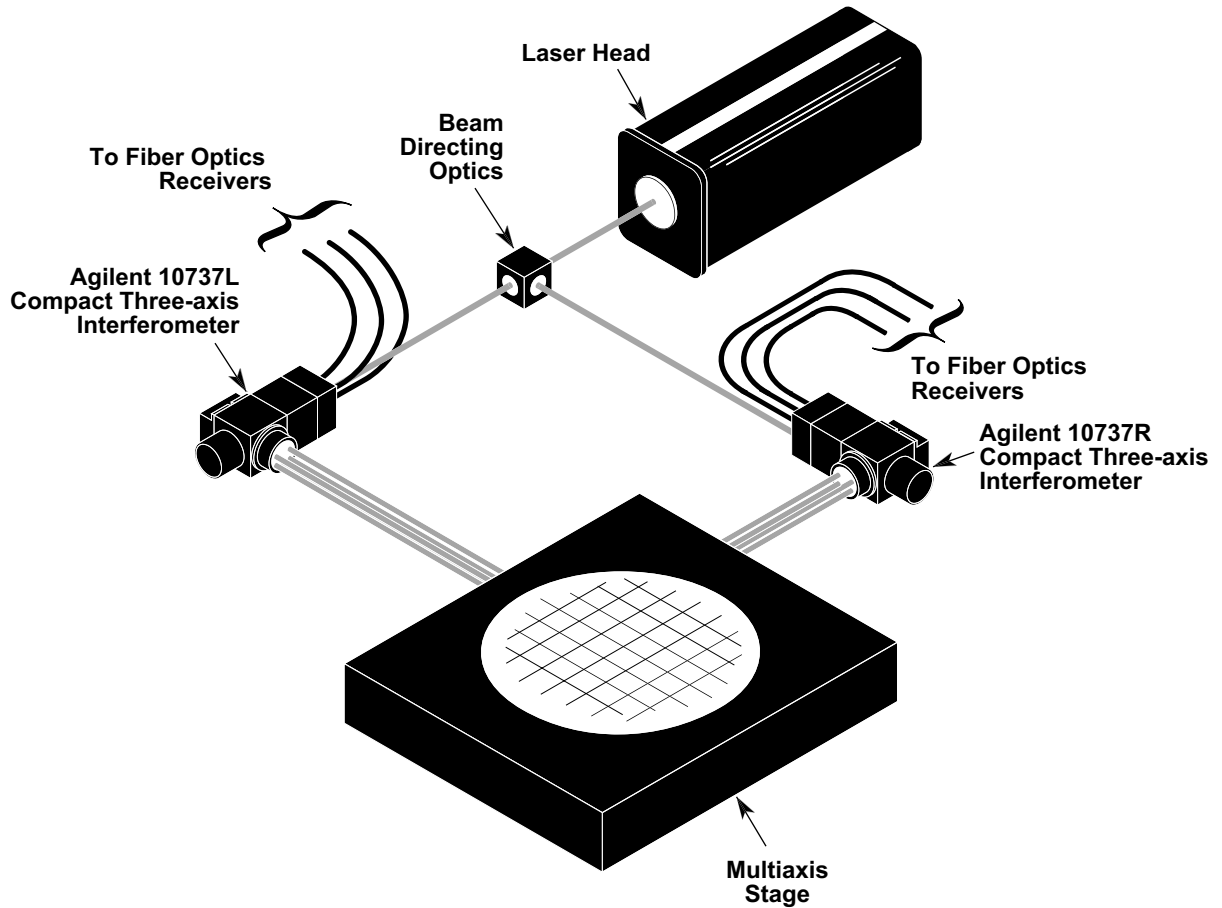

Figure 70-4. Measurement using two Agilent 10737R interferometers

Optical Schematics

Optical schematics for these interferometers are given in Figure 70-5. Each interferometer functions similarly to three parallel Agilent 10706B High Stability Plane Mirror interferometers with a three-way beam splitter in front of them.

To reduce thermal drift errors, the measurement and reference beam paths have the same optical path length in glass. This minimizes measurement errors due to temperature changes in the interferometer.

Description

MEASUREMENT PATH (f_B)

Agilent 10737L and Agilent 10737R Compact Three-Axis Interferometers

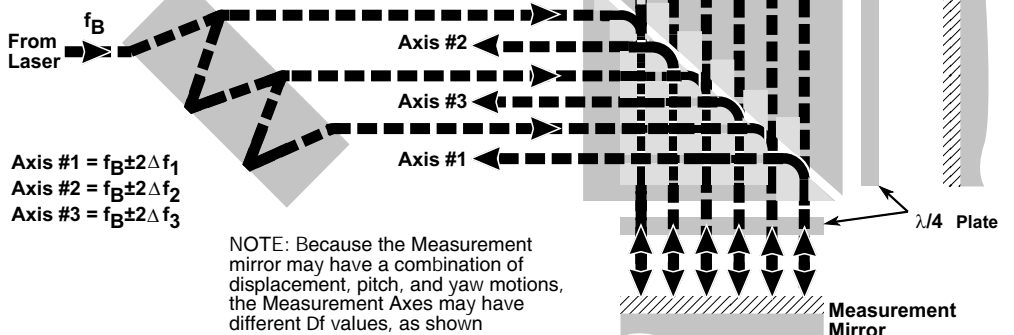

REFERENCE PATH (f_A)

Agilent 10737L and Agilent 10737R Compact Three-Axis Interferometers

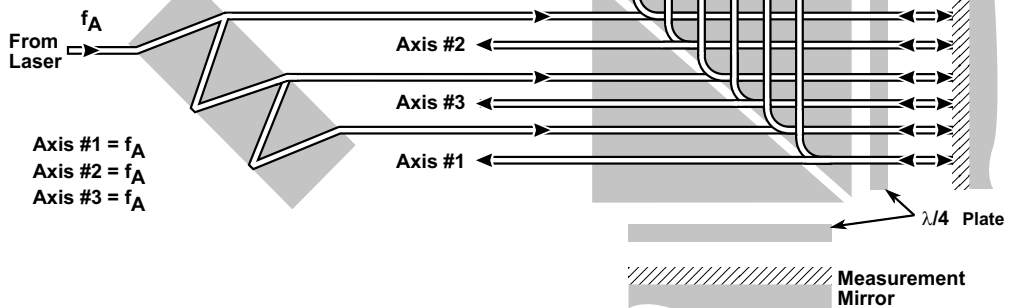

COMPOSITE (f_A) and (f_B)

Agilent 10737L and Agilent 10737R Compact Three-Axis Interferometers

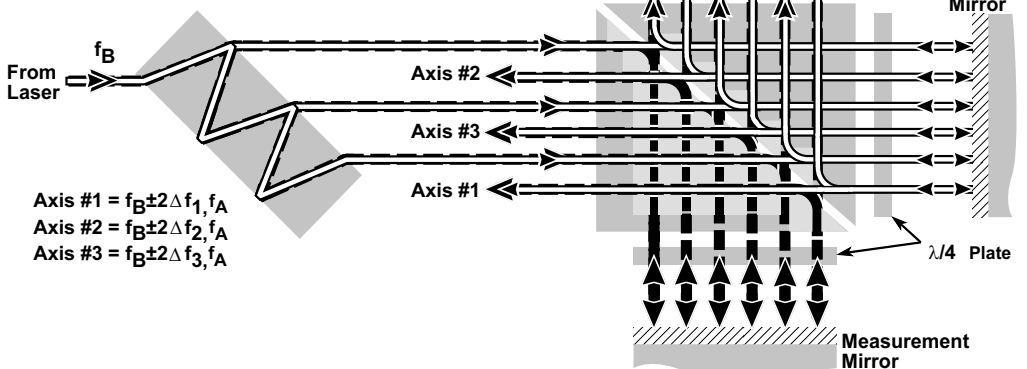

Figure 70-5. Agilent 10737L/R Compact Three-Axis interferometers — beam paths

Special Considerations

Special Considerations

Laser beam power consideration

When working with an application that requires use of a separate beam splitter, make sure that you provide enough laser beam power to any multi-axis interferometer so all receivers connected to it receive adequate light power. This will help ensure that each measurement receiver in the system receives the optimum signal strength in the intended application.

Orientation

Note that although illustrations may show an interferometer in one orientation, you may orient the unit as required by your measurement application—vertically, horizontally, or upside-down.

Special Considerations

AGILENT 10737L THREE-AXIS INTERFEROMETER

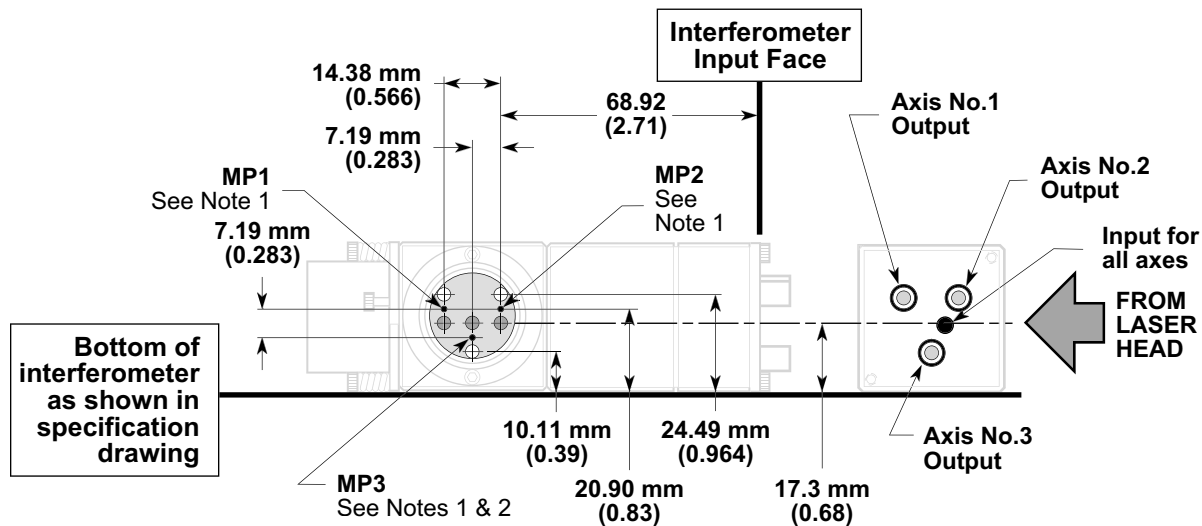

Laser Beam turns left (viewed from top).

- GENERAL NOTES:**
- For Each Axis:
 - Secondary Measurement beam
 - MP = Measurement Point
 - Darker Beam Indicates Primary Measurement beam
 - Drawing not to scale.

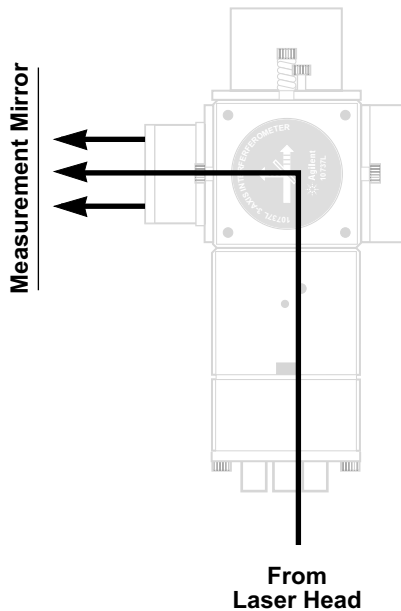
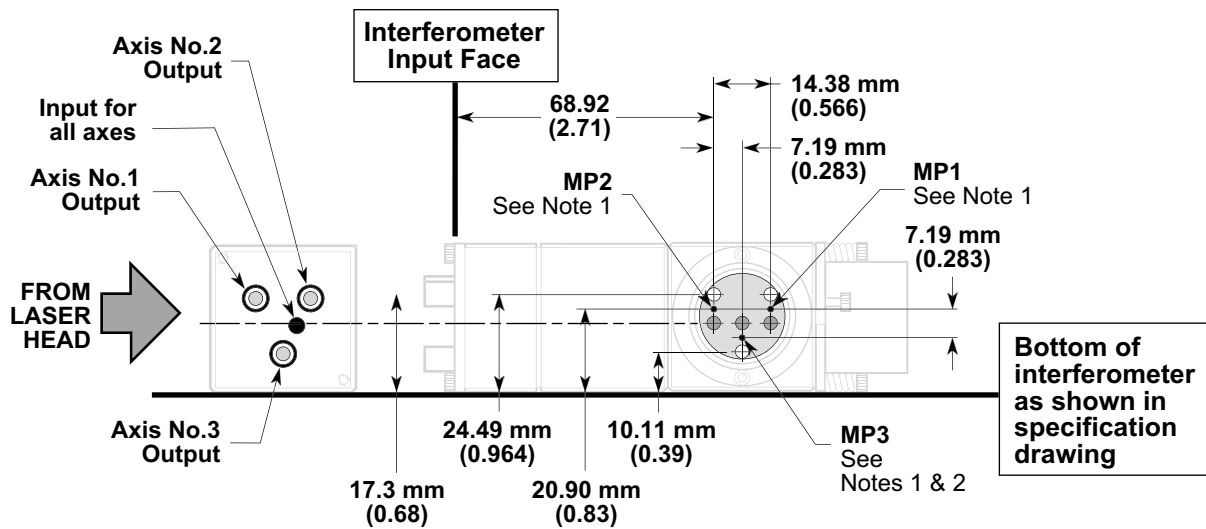

Figure 7O-6A. Agilent 10737L Interferometer — beam patterns

Special Considerations

AGILENT 10737R THREE-AXIS INTERFEROMETER



Laser Beam turns right (viewed from top).

- GENERAL NOTES:**
- For Each Axis:
 - Secondary Measurement beam
 - MP = Measurement Point
 - Darker Beam Indicates Primary Measurement beam
 - Drawing not to scale.

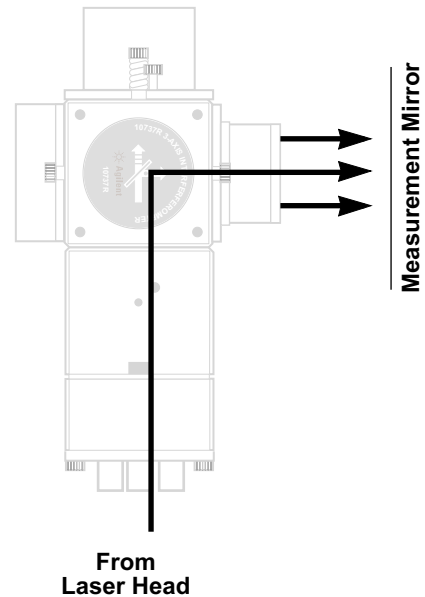

Figure 70-6B. Agilent 10737R Interferometer—beam patterns

Mounting

Mounting

Adjustable mounts

The Agilent 10711A Adjustable Mount provides a convenient means of mounting, aligning, and securely locking an Agilent 10737L or Agilent 10737R interferometer in position. Since the mount allows some tilt and yaw adjustment, the need for custom fixturing is minimized. The mount allows the interferometer to be rotated about its physical centerline, simplifying installation. Note however, that since the input aperture is not centered on the input face, some translation of the interferometer or beam delivery optics may be required when the interferometer is rotated.

Fasteners

The Agilent 10737L/R interferometers are supplied with English mounting hardware, which is required to fasten it to its adjustable mount.

Installation and Alignment

Summary

The installation and alignment procedure has two major parts:

- Planning and setting up the laser beam path(s)
- Installing and aligning the interferometer(s).

Objectives of the installation and alignment procedure are:

1. Minimizing cosine error.
2. Maximizing signal strength at the receivers.
3. Ensuring a symmetrical range of rotation about the zero angle point.

General

Refer to the Agilent 10706A interferometer “Installation” information in subchapter 7C of this manual.

Tools and Equipment Required or Recommended

Table 7O-1 lists and describes the tools and equipment needed to install and align the Agilent 10737L and 10737R interferometers.

Installation and Alignment

Table 7O-1. Tools and Equipment Required or Recommended

Item and Description	Mfr. Part Number (Mfr = Agilent unless otherwise indicated)	Comment, Note, etc.
Penta prism or similar prism that bends light exactly 90 degrees	Prisms of this type are available from scientific or optical supply shops	Recommended, but not required. For setting up right angles in the beam paths from the laser head to the interferometers. An Agilent 10777A Optical Square may be used.
True square	L.S. Starret, Athol, Mass.	Recommended, but not required. For setting up beam paths parallel to or perpendicular to machine surfaces that are parallel to or perpendicular to the stage mirrors.
Washer, lock, 0.115 in id, 0.270 in od, internal tooth; qty = 6	2190-0004	Supplied with Agilent 10737L/R Interferometer.
Screw, cap, 4-40, 0.500 in lg, hex trim head 0.187 in (3/16 in) across flats; qty = 2	2940-0269	Supplied with Agilent 10737L/R Interferometer.
Screw, machine, 4-40, 1.75 in lg, pan head, pozidriv; qty = 6	2200-0127	Supplied with Agilent 10737L/R Interferometer.
Screw, socket head cap, 4-40, 0.250 in lg, hex recess 0.094 in (3/32 in) across flats; qty = 2	3030-0253	Supplied with Agilent 10737L/R Interferometer.
Screw, socket head cap, 2-56, 0.187 in lg, 0.064 in radius oval point, hex recess; qty = 2	3030-0983	Supplied with Agilent 10737L/R Interferometer.
Hex key, 5/64 in (0.078-in)	8710-0865	Supplied with Agilent 10737L/R Interferometer.
Hex key, 3/32-in (0.094 in)	8710-0896	Supplied with Agilent 10737L/R Interferometer.
Wrench, 3/16-in open-end	8710-1740	Supplied with Agilent 10737L/R Interferometer. Used to secure the Agilent 10711A Adjustable Mount .
Alignment Aid	10706-60001	Supplied with the Agilent 10737L/R Interferometer. See Figure 7O-7 for illustration.
Alignment Aid	10706-60202	Supplied with the Agilent 10737L/R Interferometer. See Figure 7O-7 for illustration.

Installation and Alignment

Alignment aid (Agilent Part Number 10706-60001) is the same as one used on the Agilent 10706B Plane Mirror Interferometer. Refer to the “Alignment aids” section for the Agilent 10706B Plane Mirror Interferometer, in subchapter 7C of this manual for a further discussion of its use.

Alignment aid (Agilent Part Number 10706-60202), shown in Figure 7O-7, facilitates autoreflection alignment for the high stability adapter to achieve minimal thermal drift. It contains a quarter-wave plate which allows the reference beam to return to the laser head without offset. Figure 7O-10 illustrates how the aid is positioned between the beam splitter and the high stability adapter during alignment.

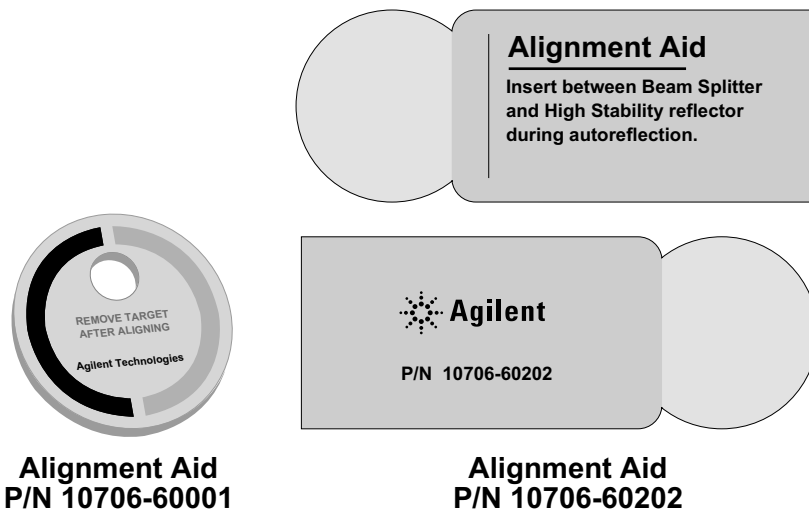

Figure 7O-7. Agilent 10737L/R interferometers—alignment aids

Procedure

Procedure

Planning the measurement setup

Determine the general plan for your measurement. Examples of measurement setups are given throughout this manual. Particularly, your plan should address:

1. Which axes you want to measure, and what measurements you want to make,
2. Where the interferometers will be positioned with respect to the stage mirrors,
3. Where the laser head will be positioned and how the laser beam will be delivered to the interferometers, and
4. Making sure you will have enough laser power to drive all receivers in your measurement system.

Good practice defines the plane and direction of all beam paths against machined surfaces known to be parallel or perpendicular to the stage plane.

You may need to provide special mounting arrangements for the laser head and the optics in order to place the measurement beams where you want them on the stage mirrors.

Initial installation and setup

- 1 Install the laser head, the beam-steering optics, and the beam-splitting optics in their general locations, as specified in your plan. The interferometer(s) will be installed after the beam paths have been established as described below.
- 2 Turn on power to the laser head and select the laser head's small output aperture.
- 3 Refer to Chapter 4, "System Installation and Alignment," in this manual, beginning with the "Alignment principles" section, for additional information about aligning your measurement setup.

Procedure

Installing and aligning an interferometer

CAUTION

In performing the procedure below, perform only the removal, disassembly or assembly steps described. Do not remove or take apart anything you are not instructed to. Do not touch any glass surface or allow it to be scratched, dirtied or otherwise harmed.

CAUTION

Do not touch any glass surface of any optic. For cleaning instructions, see Chapter 10, "Maintenance," in this manual.

Perform this procedure for each interferometer in your measurement system.

This procedure assumes that the laser head and all optics except the interferometer(s) have been installed and that the appropriate beam path(s) to the stage mirror(s) have been established as described in Chapter 4, "System Installation and Alignment," of this manual.

The procedure has these major parts:

1. Removing the receiver assembly
2. Removing the high stability adapter (reference mirror)
3. Aligning the measurement beam path
4. Aligning the reference beam path
5. Comparing beam path alignments

Removing the receiver assembly

To remove the receiver assembly, refer to figures 7O-1 and 7O-8.

- 1** Use the 5/64-inch hex key to remove the two cap screws that hold the receiver assembly to the interferometer. Set the screws in a clean, safe place where they will not be lost.
- 2** Remove the receiver assembly from the interferometer. Set the receiver assembly in a clean, safe place.

Procedure

Removing the high stability adapter (reference mirror)

To remove the high stability adapter, refer to figures 7O-1 and 7O-8, and:

- 1** Use the 5/64-inch hex key to remove the two cap screws with springs that hold the high stability adapter (reference mirror) to the interferometer. Set the screws in a clean, safe place where they will not be lost.
- 2** Remove the high stability adapter (reference mirror) from the interferometer. Set the high stability adapter in a clean, safe place.

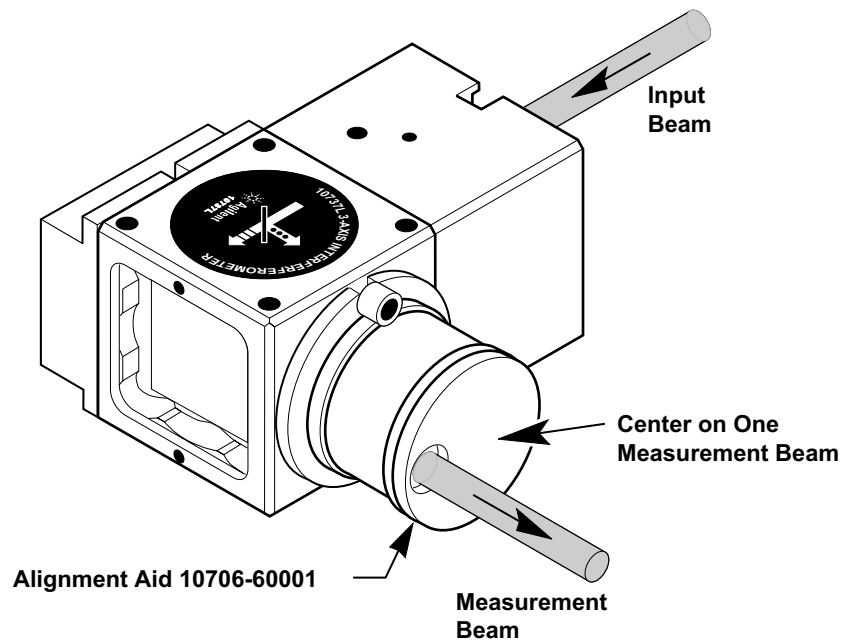

Figure 7O-8. Agilent 10737L Compact Three-Axis Interferometer with Agilent 10706-60001 Alignment Aid

NOTE

From here on, this procedure assumes that the interferometer is installed on an Agilent adjustable mount.

Procedure

Aligning the measurement beam path

- 1** Remove the receiver assembly and high stability adapter, as described in the respective procedures, above.
- 2** Install the interferometer so the beam from the laser source enters its input aperture and is normal to its input face.
- 3** Set the alignment aid (Agilent Part Number 10706-60001) on the interferometer's Measurement beam aperture as shown in Figure 7O-8.

With the alignment aid installed, the beam will be reflected off the stage mirror back to the laser head.

- 4** Set the laser head to the small aperture.
- 5** Roll and yaw the interferometer until the autoreflected beam is centered on the small aperture of the laser.
- 6** Select the laser head's large output aperture and translate the interferometer horizontally until the input beam is centered on the interferometer's input aperture.

A piece of translucent tape over the interferometer's input aperture will make the input beam visible. This procedure assumes that the vertical height of the beam was set before the interferometer was installed, (see the "Initial installation and setup" procedure); alternatively, fixturing for a vertical adjustment for the interferometer may be used.

- 7** Select the laser head's small output aperture and check that the beam is still autoreflecting.
- 8** Repeat steps 3 through 7 until the beam is both autoreflecting and centered on the interferometer's input aperture.
- 9** Tighten all mount adjustment screws.
- 10** Remove the alignment aid.
- 11** Check the position of the beams in the interferometer's output apertures (see Figure 7O-9).

Once again, translucent tape is helpful for viewing the beams in the apertures. If any beam clipping occurs, or if the beams are far off from the desired location, check for obstructions and recheck the alignment (by performing steps 3 through 7 above).

Procedure

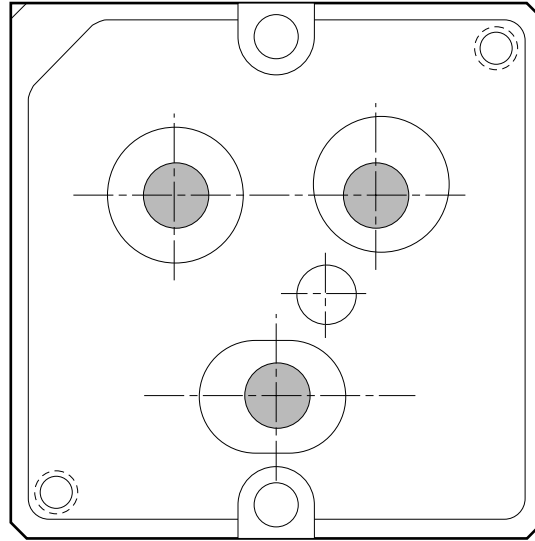

Figure 7O-9. Agilent 10737L Compact Three-Axis Interferometer — return beam pattern

- 12** Install the receiver assembly.

To do this, reverse the “Removing the receiver assembly” procedure, above.

- 13** Plug in the fiber-optic cables.

- 14** Adjust each receiver’s gain by turning its gain adjustment screw to cause the receiver’s LED to light, then reduce the gain until the LED just turns off. For more information, see Agilent 10780F instructions in Chapter 8, “Receivers,” of this manual.

Procedure

Aligning the reference beam path

NOTE

The measurement path must be aligned and the laser beam centered on the input aperture before aligning the reference mirror.

- 1 Remove the receiver assembly and the plane mirror converter (see figures 7O-1 and 7O-4), and set aside on a clean surface. Do not touch any glass surface of any optic.

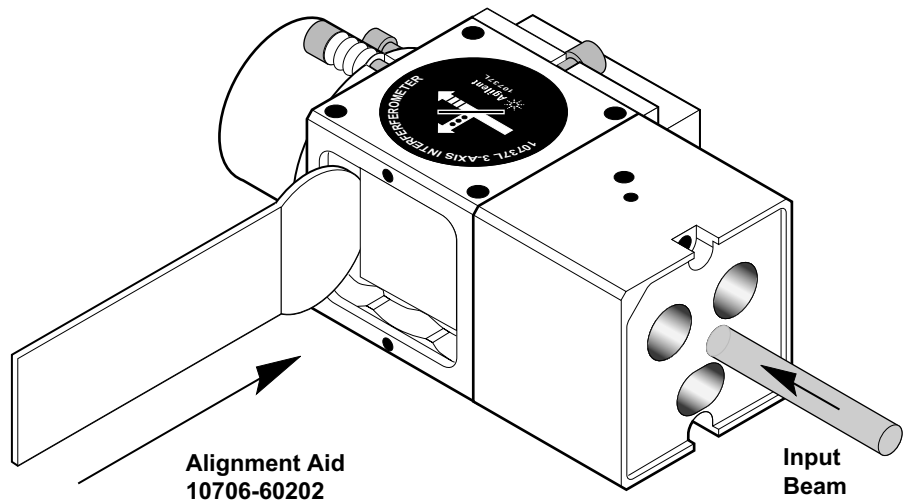

Figure 7O-10. Agilent 10737L Compact Three-Axis Interferometer with 10706-60202 Alignment Aid

- 2 Install the reference mirror assembly (see figures 7O-1 and 7O-4).

The 4-40 screws on springs hold the mirror in place. The four 2-56 screws tilt the mirror for alignment. Back off the 2-56 screws so the mirror housing is flush with the interferometer. Tighten the 4-40 screws to compress the springs completely and then back off approximately 1-1/2 turns.
- 3 Place the 10706-60202 alignment aid between the beam splitting cube and the reference mirror (see Figure 7O-10).
- 4 Block the beams going to the stage mirror.
- 5 Set the laser to the small aperture.

Procedure

- 6** Tilt the reference mirror by adjusting the 2-56 screws until the beam from the reference mirror autorefects back to the center of the laser small aperture.
- 7** Remove the alignment aid.
- 8** Check the position of the beams in the interferometer's output apertures (see Figure 7O-9).

Once again, translucent tape is helpful for viewing the beams in the apertures. If any beam clipping occurs, or if the beams are far off from the desired location, check for obstructions and recheck the alignment (by performing steps 6 through 10 above).

- 9** Install the receiver assembly.

To do this, reverse the "Removing the receiver assembly" procedure, above.

- 10** Plug in the fiber-optic cables.
- 11** Adjust each receiver's gain by turning its gain adjustment screw to cause the receiver's LED to light, then reduce the gain until the LED just turns off. For more information, see Agilent 10780F instructions in Chapter, 8, "Receivers," of this manual.
- 12** Unblock the stage mirror beams.

Comparing beam path alignments

- 1** Remove the receiver assembly.
- 2** Look for any lack of overlap between the reference and measurement return beams, translucent tape will help. If beams do not overlap, check reference mirror alignment.

Note that if you must realign the measurement mirror, you will also have to realign the reference mirror.

- 3** Install the receiver assembly and make sure all screws are tight.

Operation

Operation

Measurements

For an interferometer setup to measure distances along the X-axis, measurements of displacement, pitch, and yaw are derived as described below. These computations are done via software on the system controller or computer.

Displacement

For the Agilent 10737L/R interferometer, displacement along the X-axis can be measured as the average of the data returned from measurement axis #1 and measurement axis #2.

$$\text{Displacement} = \frac{\text{measurement axis \#1} + \text{measurement axis \#2}}{2}$$

Pitch

For the Agilent 10737L/R interferometer, pitch (rotation about the Y axis) can be measured using data returned from all three measurement axes, and the vertical offset between the common centerline of measurement axes #1 and #2 and the centerline of measurement axis #3 (7.19 mm, or 0.283 inch).

$$\text{Pitch} = \frac{\text{Displacement} - \text{measurement axis \#3}}{7.19 \text{ mm or } 2.83 \text{ inch}} \text{ radian}$$

Yaw

For the Agilent 10737L/R interferometer, yaw (rotation about the Z axis) can be measured as the difference between the data returned from measurement axis #1 and measurement axis #2, divided by the distance between them (14.38 mm, or 0.566 inch).

$$\text{Yaw} = \frac{\text{measurement axis \#1} - \text{measurement axis \#2}}{14.38 \text{ mm or } 0.5666 \text{ inch}} \text{ radian}$$

Error

The deadpath distance for an Agilent 10737L/R interferometer is the distance between the interferometer's measurement face and the measurement mirror, at the measurement "zero" position. This is the same as for the Agilent 10706B interferometer, on which it is based.

Specifications and Characteristics

Specifications and Characteristics

Specifications describe the device's warranted performance. Supplemental characteristics (indicated by TYPICAL or NOMINAL) are intended to provide non-warranted performance information useful in applying the device.

Plane mirror systems have a fundamental optical resolution of one quarter wavelength (0.158 micron, 6.23 microinches).

Using electronic resolution extension, the system resolution is increased significantly. Depending on the system, an additional resolution extension factor of 32 (for Agilent 10885A and 10895A) or 256 (for Agilent 10897B and 10898A) is usually available.

Interferometer	Fundamental Optical Resolution	System Resolution (see NOTE)
Agilent 10737L or Agilent 10737R	$\lambda/4$ (158.2 nm, 6.2 μin)	See specifications on following page.

Specifications and Characteristics

Agilent 10737L/R Compact Three-Axis Interferometer Specifications

Linear Resolution:	5 nm (using Agilent 10885A, or Agilent 10895A electronics) 0.6 nm (using Agilent 10897A, or Agilent 10898A electronics)
Yaw Resolution:	0.35 μ rad (0.07 arc-sec) (using Agilent 10885A, or Agilent 10895A electronics) 0.04 μ rad (0.01 arc-sec) (using Agilent 10897A, or Agilent 10898A electronics)
Pitch and Roll Resolution:	0.7 μ rad (0.14 arc-sec) (using Agilent 10885A, or Agilent 10895A electronics) 0.1 μ rad (0.02 arc-sec) (using Agilent 10897A, or Agilent 10898A electronics)
Yaw Range*:	± 0.44 mrad (± 1.5 arc-min)
Pitch and Roll Range:	± 0.44 mrad (± 1.5 arc-min)
Linear Range:	10 m (33 ft) total for all three axes.
Operating Temperature:	0–40 °C (17–23 °C to ensure system non-linearity specification)
Thermal Drift Coefficient:	Same as Agilent 10706B
Weight:	490 g (18 oz)
Dimensions:	see Figure 7O-11 on the next page
Materials Used:	Housing: stainless steel and aluminum Optics: optical grade glass Adhesives: vacuum grade, cyanoacrylate polarizer material Receiver inserts: urethane foam, acetal, 15% glass fill polyester
Installation:	Uses 3-mm beam available from Agilen 5517C-003. Requires three Agilent 10780F-037 Remote Receivers. Compatible with Agilent 10711A Adjustable Mount.
Measurement (Plane) Mirror Recommendations:	Reflectance: 98% at 633 nm at normal incidence Flatness: Flatness deviations will appear as measurement errors when the mirror is scanned perpendicular to the beam. Recommended range 1/4 (0.16 μ m or 6 μ in) to 1/20 (0.03 μ m or 1.2 μ in) dependent on accuracy requirements.
Optical Surface Quality:	60-40 per Mil 0-13830

* At a distance of 300 mm, maximum measurement mirror angle due to all components (i.e., yaw and pitch or yaw and roll) between the measurement mirror and the interferometer. A six-axis system is assumed.

Specifications and Characteristics

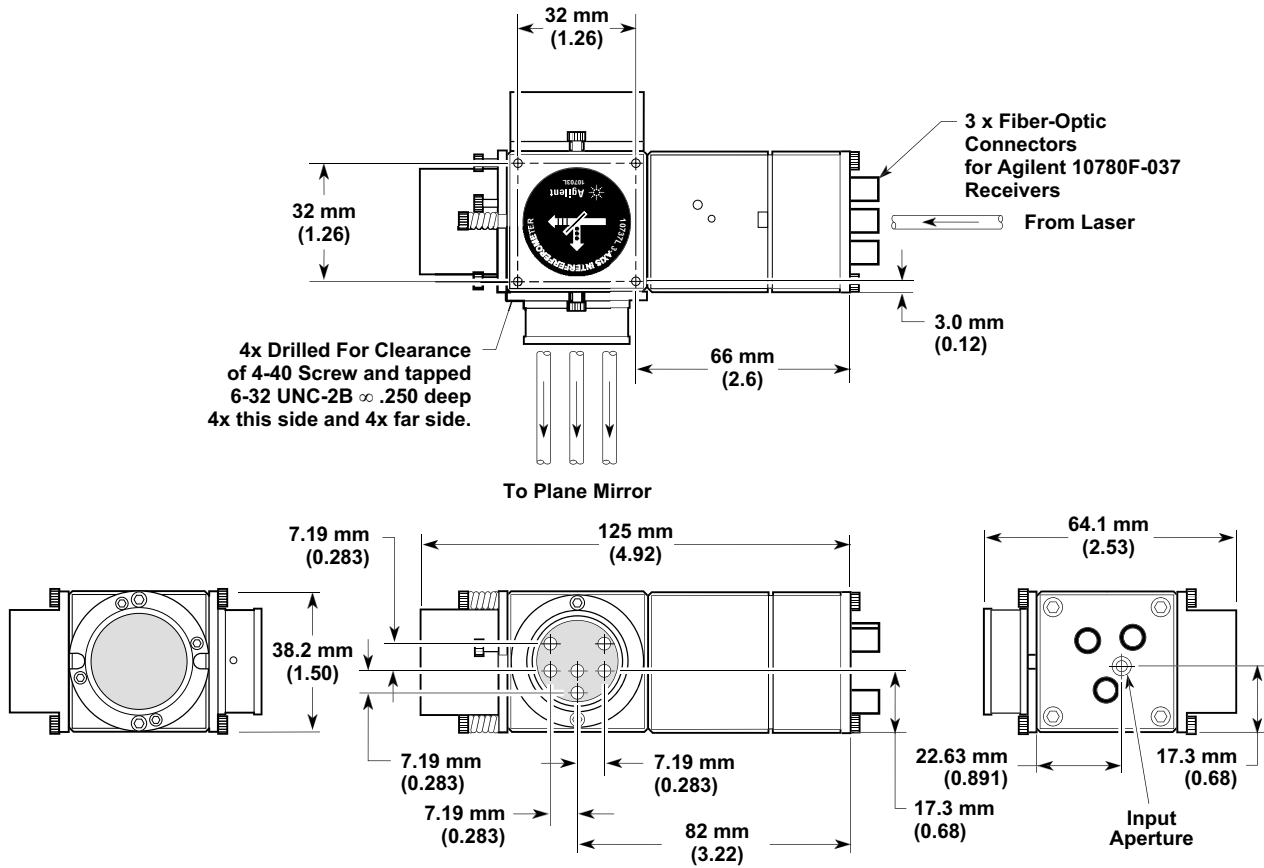

Agilent 10737L interferometer is shown; Agilent 10737R interferometer dimensions are similar.

Figure 7O-11. Agilent 10737L/R Compact Three-Axis Interferometer — dimensions

Product specifications and descriptions in this document subject to change without notice.
 Copyright (C) 2002 Agilent Technologies
 Printed in U.S.A. 07/02
 This is a chapter from the manual titled:
 Laser and Optics User's Manual
 For complete manual, order:
 Paper version: p/n 05517-90045
 CD version: p/n 05517-90063
 This chapter is p/n 05517-90122